

Magnetful 100

100 kg
Weight Capacity
3.000 mm
Working Radius

Magnetful 50

50 kg
Weight Capacity
2.500 mm
Working Radius

Combined power of Pneumatic & Magnetic Lifting

Due to the perfect load distribution, Magnetful enable almost weightless lifting and handling in all directions with a wide range of different loads.

Pneumatically activated magnets and safety features make our products versatile and a powerful choice for industries such as manufacturing, assembly, logistics, and material handling.

They work with dry, filtered (40 µm) and oil-free compressed air.





Magnetful 50

Weight Capacity: 50 kg
 Working Radius: 2500 mm
 Vertical Lift: 1600 mm
 Pressure: 0,7-0,8 MPa
 Air Consumption: 21 nl/min



Magnetful 100

Weight Capacity: 100 kg
 Working Radius: 3000 mm
 Vertical Lift: 1800 mm
 Pressure: 0,7-0,8 MPa
 Air Consumption: 50 nl/min

Flexible

Magnetful can grab loads from the top or the side. It can be used to lift loads in different sizes and shapes.

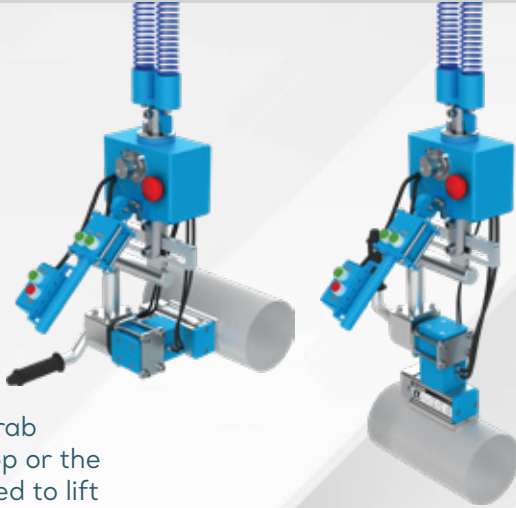

Safe

Operator can't turn the magnet off while the load is lifted. Magnet can be turned off only when the load is safely on the surface.

The system does not permit lifting unless the magnet is placed in the correct position and fully activated.

The Magnet

Designed for use with air operated hoists. Pneumatically activated and disabled. Each model also has an emergency release, so you always have full control.

Model	Max. Load capacity (kg)		Max. Load capacity from (mm)	Dimensions (mm)						Weight (kg)
	flat	round		L	B	H	H1	R	X/Y	
FX-R100 Pneumatic	80 kg	Ø25-150 mm 80 kg	8	195	64	241	311	134	30/42	5,5
FX-R225 Pneumatic	225 kg	Ø50-205 mm 225 kg	10	265	87	295	376	188	42/53	13

Safety factor 3,5/Test method EN 13155 max. Operation temperature 80°C

