



PM Hercules

Pneumatic Manipulator with Rigid Arms



*Hercules Pneumatic Manipulator,
1.200 kg carrying capacity version,
displayed with the paper coil fixture.*

Hercules Pneumatic Manipulators are designed to move operator-centered loads within the work area with minimum effort. It balances the weight of the load, allowing the operator to carry the load quickly and safely.

Manipulators, either floor mounted or ceiling mounted. Hercules is equipped with special gripping tools which are particularly suitable to manually handle center offset loads in any direction, in a weightless condition. The manipulator, which consists of two arms, has a total of two brakes on the arm rotation axis. It's versatile structure allows it to fit in any working environment.

Works with dry, filtrated (40 μm) and oil free compressed air (min. 0.7/0.8 MPa).

1.200 kg max. weight capacity. **4.500 mm** max. radius. **2.200 mm** vertical lift.
475 nl/min max. air consumption.

Mounting Options

Hercules Column Mounted *HY*



Hercules Overhead Mounted *HT*

Hercules-01

Hercules Overhead Trolley Mounted *HTA*

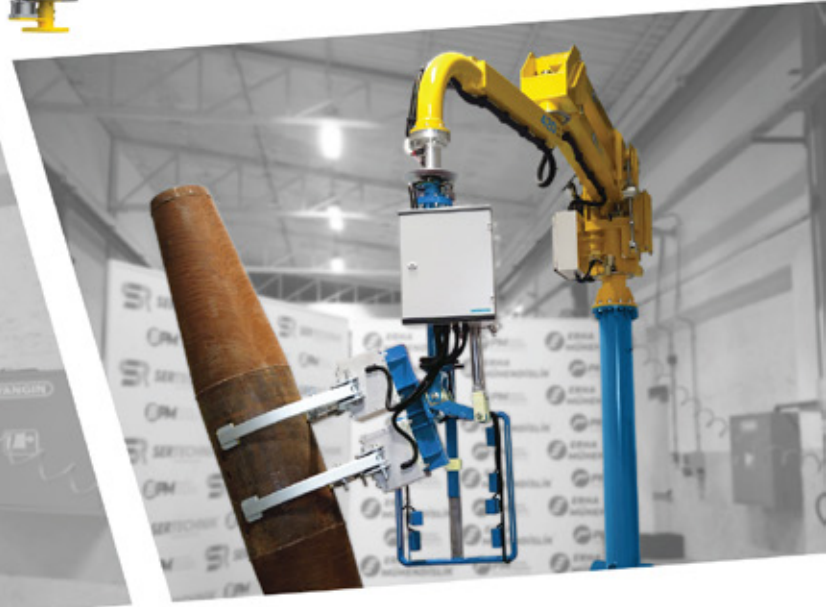
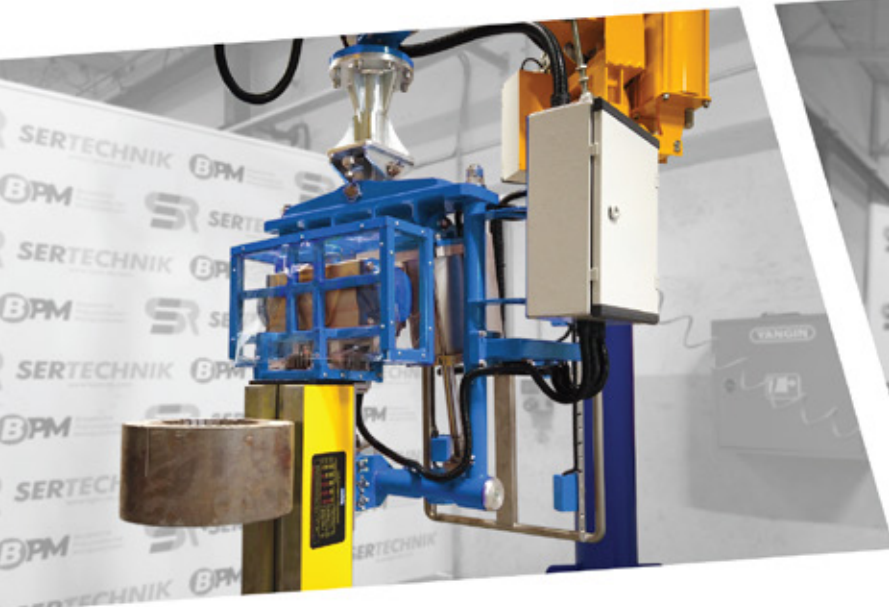

Hercules Technical Details

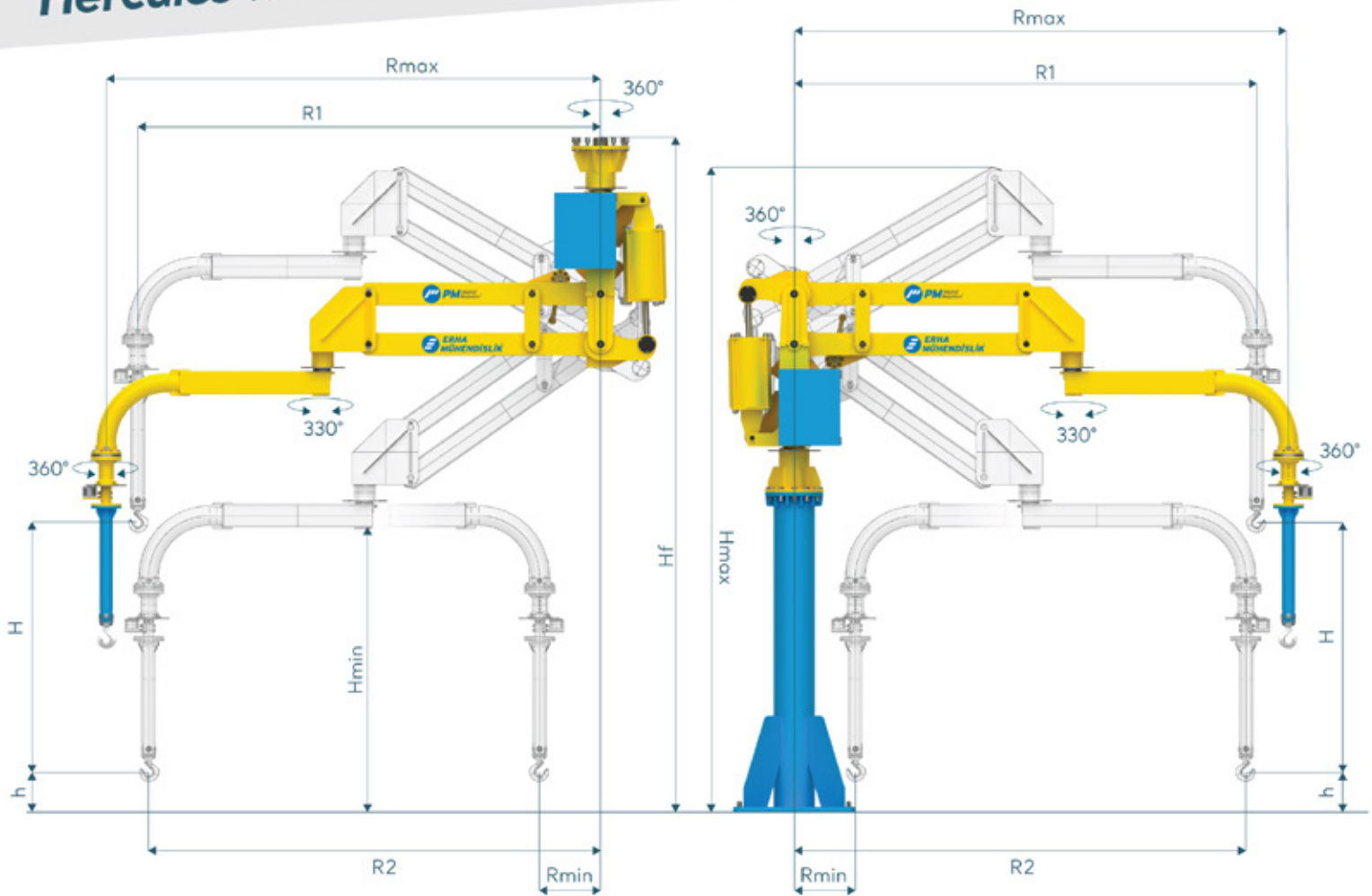

Weight Capacity / kg		1200	1000	700	700	600
Max. Radius / mm	Rmax	2500	3000	3500	4000	4500
Min. Radius / mm	Rmin	832	882	990	1049	1167
Vertical Lift / mm	H	1400	1625	1900	2050	2200
Min. Vertical Lift / mm	*h	200	200	200	200	200
Max. Height / mm	*Hmax	4152	4375	4650	4800	4949
Max. Ceiling Height / mm	*Hf	4300	4415	4545	4616	4690
Min. Height / mm	*Hmin	2000	2000	2000	2000	2000
Radius 1	R1	2302	2771	3232	3711	4190
Radius 2	R2	2254	2715	3166	3640	4114

* Marked dimensions can change according to the customer request.

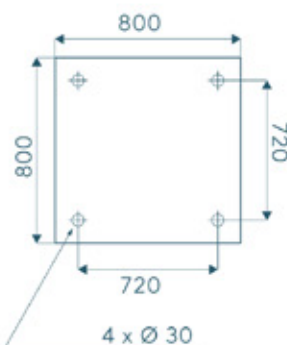

Mounting Plate Dimensions (mm)