

PM Forceful
Pneumatic Manipulator with Rigid Arms



*Forceful Pneumatic Manipulator,
450 kg carrying capacity version,
displayed with the vacuum operated fixture
designed to carry glass panels.*

Forceful Pneumatic Manipulators are designed to move operator-centered loads within the work area with minimum effort. It balances the weight of the load, allowing the operator to carry the load quickly and safely.

Manipulators, either floor mounted or ceiling mounted. Forceful is equipped with special gripping tools which are particularly suitable to manually handle center offset loads in any direction, in a weightless condition. The manipulator, which consists of two arms, has a total of two brakes on the arm rotation axis. It's versatile structure allows it to fit in any working environment.

Works with dry, filtrated (40 μm) and oil free compressed air (min. 0.7/0.8 MPa).

450 kg max. weight capacity. **4.000 mm** max. radius. **2.450 mm** vertical lift.
140 nl/min max. air consumption.

Mounting Options

Forceful Column Mounted FY



Forceful Overhead Mounted FT



Forceful Overhead Trolley Mounted FTA

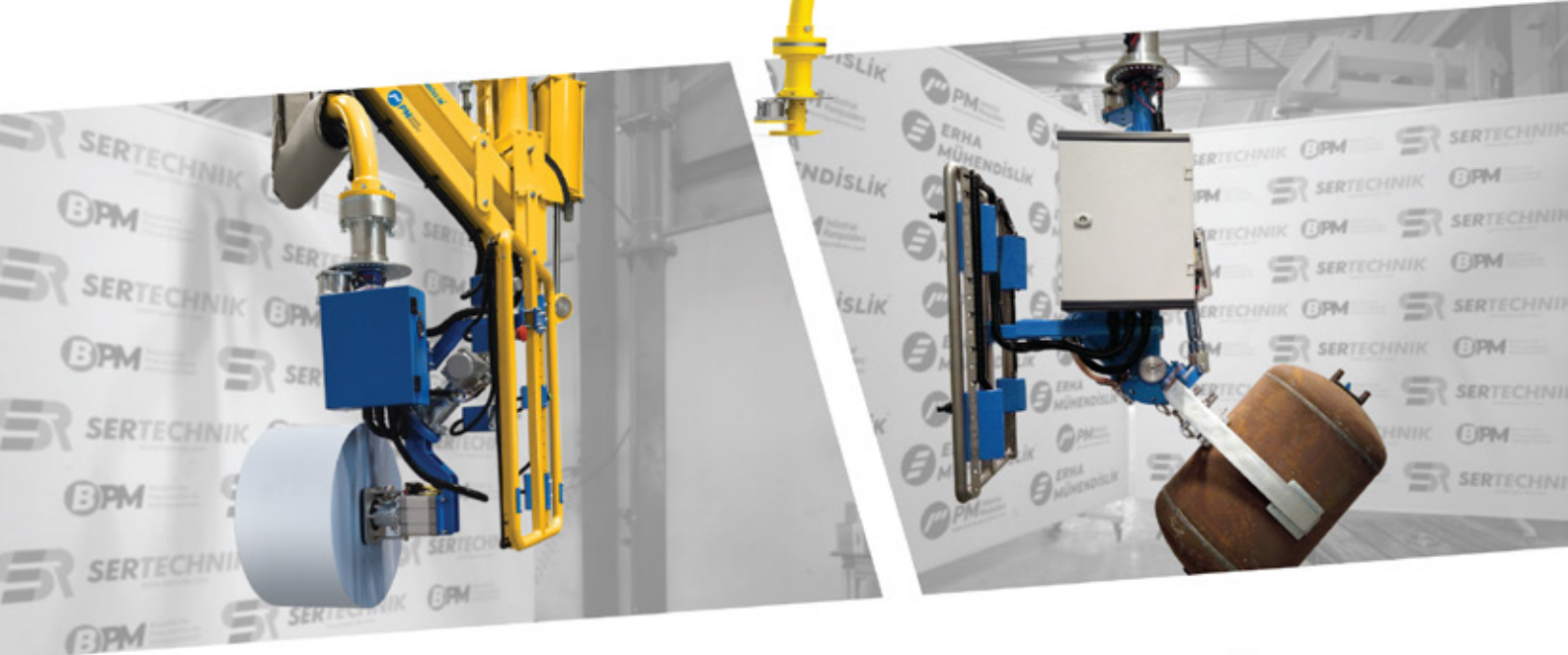

Forceful Technical Details

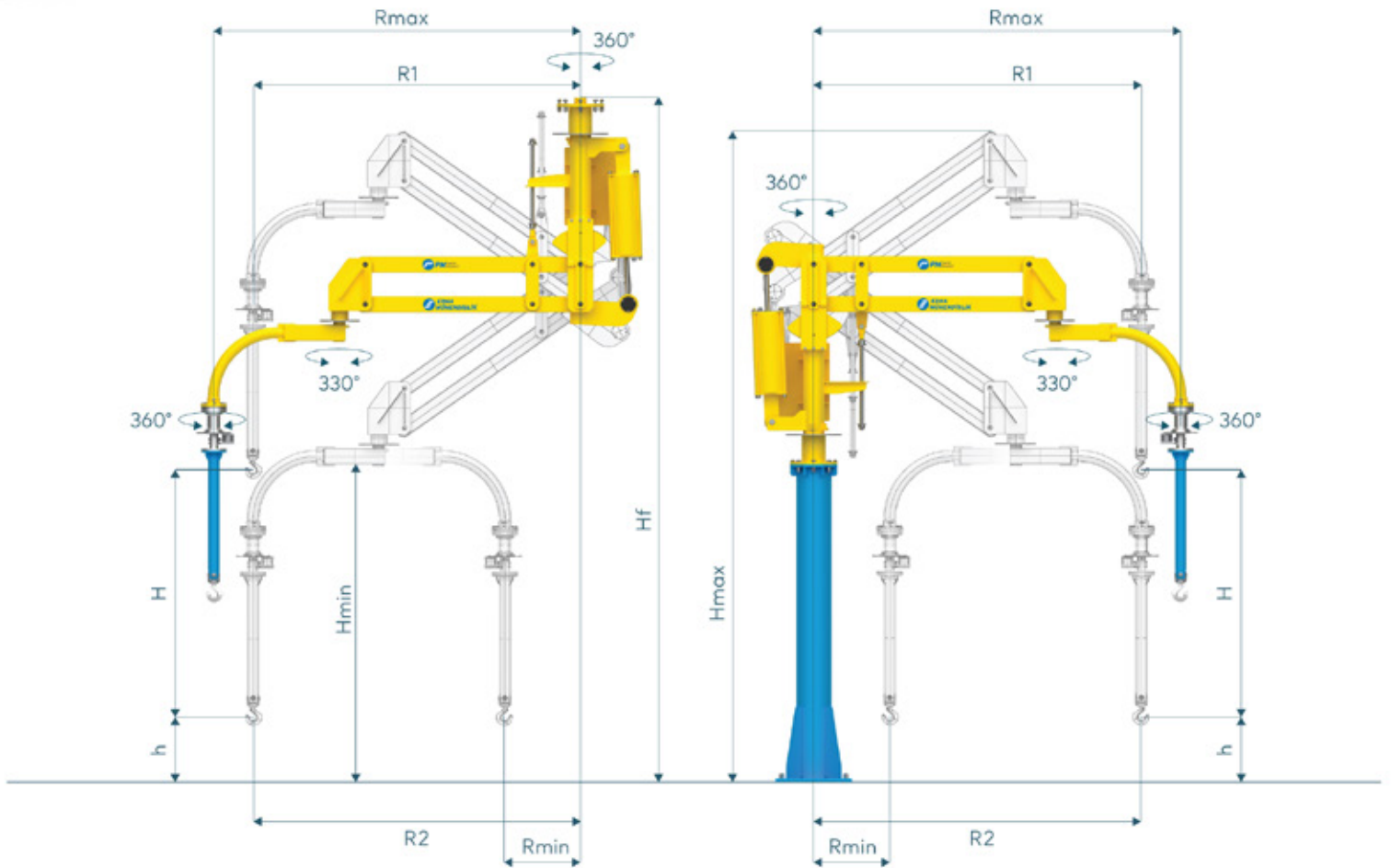

Weight Capacity / kg		450	300	215	150	100
Max. Radius / mm	Rmax	2000	2500	3000	3500	4000
Min. Radius / mm	Rmin	580	755	850	1000	1150
Vertical Lift / mm	H	1300	1700	2000	2400	2450
Min. Vertical Lift / mm	*h	200	200	200	200	200
Max. Height / mm	*Hmax	3860	4070	4225	4420	4610
Max. Ceiling Height / mm	*Hf	4100	4100	4800	5000	5000
Min. Height / mm	*Hmin	2000	2000	2000	2000	2000
Radius 1	R1	1750	2170	2610	3035	3465
Radius 2	R2	1750	2170	2610	3035	3465

* Marked dimensions can change according to the customer request.

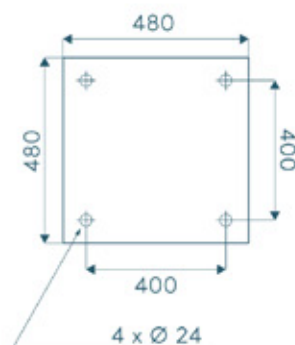

Mounting Plate Dimensions (mm)