



## **PM Helpful**

Pneumatic Manipulator with Double Rope System



## Pneumatic Manipulators with Double Rope System



Helpful Pneumatic Manipulators are designed to move operator-centered loads within the work area with minimum effort. It balances the weight of the load, allowing the operator to carry the load quickly and safely.

The balance of the load to be carried is provided by connecting two steel cables to the balance unit. Manipulators, either floor mounted or ceiling mounted. Manipulators are produced with standard hooks, but they can also be produced with special holders designed according to needs. The manipulator moves under aluminium rails which makes it easy to handle and gives precision throughout the working area.

Works with dry, filtrated (40  $\mu\text{m}$ ) and oil free compressed air (min. 0.7/0.8 MPa).

**180 kg** max. weight capacity. **6.000 mm** max. radius. **1.600 mm** vertical lift.  
**68 nl/min** max. air consumption.

## Mounting Options

### Helpful Jib Arm HP

#### Weight Capacity / kg

Max. Radius / mm

Min. Radius / mm

Vertical Lift / mm

Min. Vertical Lift / mm

Max. Height / mm

Min. Height / mm

Rmax

Rmin

H

\*h

\*Hmax

\*Hmin

90 / 180

4000 / 6000

1350

1600

200

3870

2600

\* Marked dimensions can change according to the customer request.

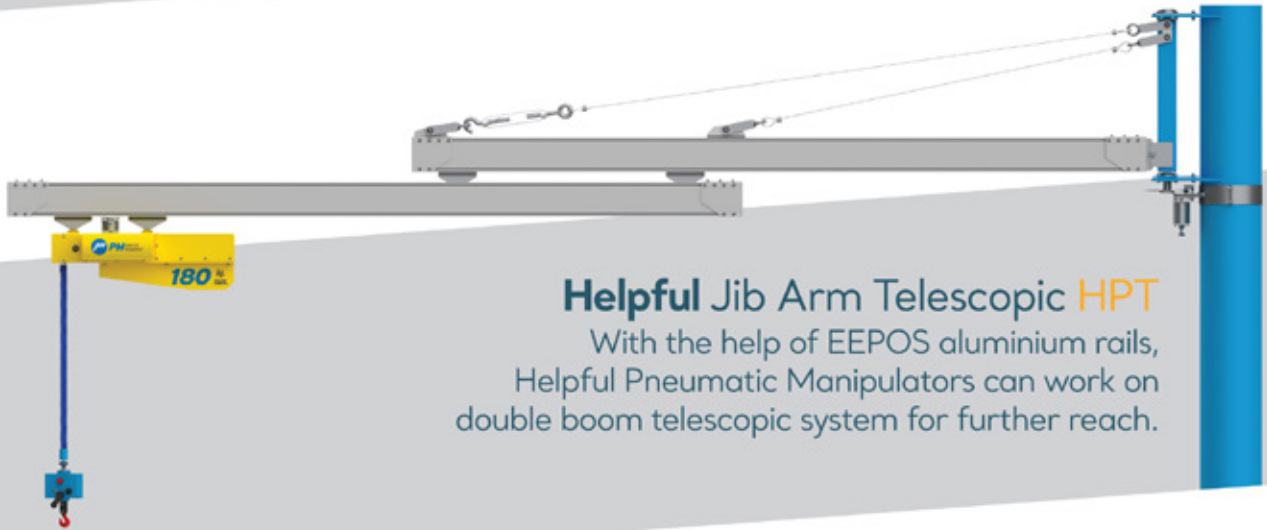

### Helpful Jib Arm Telescopic HPT

With the help of EEPOS aluminium rails, Helpful Pneumatic Manipulators can work on double boom telescopic system for further reach.

### Helpful Rail System HR

With our partnership with EEPOS Cranes, we can deliver special designs for your special needs.

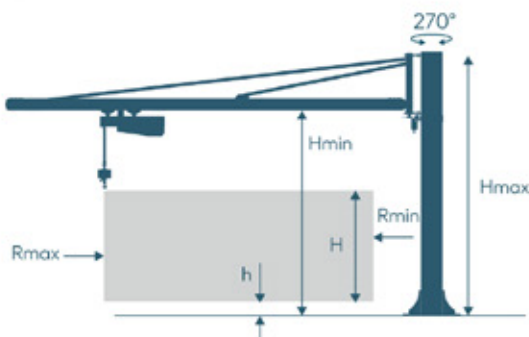
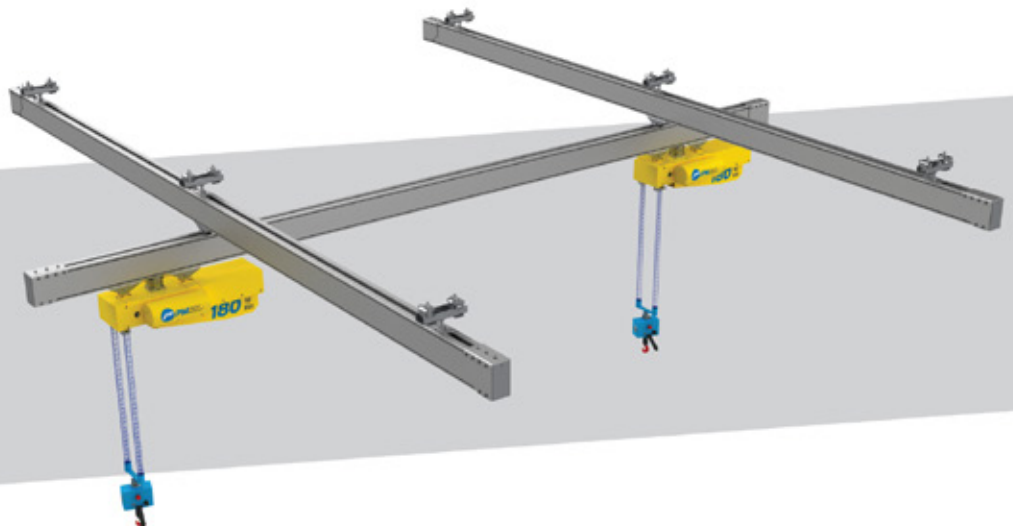

Mounting Plate Dimensions (mm)

